

# A State-Free Data Delivery Protocol for Multihop Wireless Sensor Networks

Dazhi Chen  
Department of EECS  
Syracuse University  
Syracuse, NY 13244  
dchen02@syr.edu

Jing Deng  
Department of CS  
University of New Orleans  
New Orleans, LA 70148  
jing@cs.uno.edu

Pramod K. Varshney  
Department of EECS  
Syracuse University  
Syracuse, NY 13244  
varshney@ecs.syr.edu

**Abstract**—A novel, state-free, and competition-based data delivery protocol, called State-free Implicit Forwarding (SIF), is proposed for multihop wireless sensor networks. The SIF protocol assumes moderate node density and distance-to-sink awareness. The state-free feature of SIF makes it robust to high network dynamics. SIF also combines the tasks of routing and MAC, via cross-layer design, to simplify the complexity of the protocol stack in sensors and to save precious network resources. Simulation results are presented to show that SIF performs better than some previously proposed protocols for data delivery in terms of communication overhead, packet delivery ratio, and average packet delay.

## I. INTRODUCTION

In recent years, wireless sensor networks (WSNs), comprised of a large number of networked small sensors with computation, communication, sensing, and possible location-capabilities, have emerged as a new information-gathering paradigm [1]. Although envisioned applications for WSNs remain diverse, they all require a completely new data delivery mechanism suitable for the specific characteristics of WSNs, since most applications of WSNs rely on sensing data to make mission-critical decisions. In this work, we present a novel data delivery protocol for WSNs, which can effectively deliver sensing data from sensors to data sinks via multiple hops.

It is well known that energy is a primary concern in resource-constrained WSNs. In [2], communication has been identified as the major source of energy consumption and costs significantly more than computation. Thus, it is vital to minimize the number of bits transmitted during data delivery since every bit transmitted reduces the lifetime of the network. The bits transmitted during data delivery include sensing data and overhead that is required to maintain inter-node communications. Thus, one of the main tasks of an efficient data delivery protocol is to reduce communication overhead as much as possible.

Currently, data delivery protocols for sensor networks presented in the literature can be broadly classified<sup>1</sup> as shown in

This work was partially supported by the SUPRIA program of the CASE center at Syracuse University.

<sup>1</sup>Data delivery means the entire network task of delivering the desired sensing data to data sinks. It can be implemented by an individual protocol or by a set of protocols such as routing and MAC protocols together. The above classification includes some protocols that only provide the routing function.

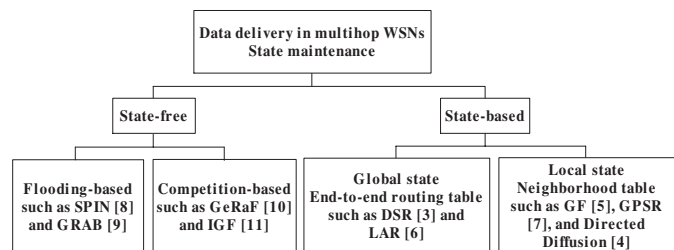

Fig. 1. A simple classification of data delivery protocols in WSNs

Fig. 1, from the viewpoint of state maintenance.<sup>2</sup> Most state-based data delivery protocols [3]–[7] for WSNs, which must update and maintain neighborhood or routing tables, lead to a large amount of communication overhead. These techniques consume much precious energy and bandwidth. Furthermore, the high dynamics in WSNs, arising from sensor failures, wireless link failures, node mobility, and even sensor state transitions due to the use of power management or energy efficient schemes, make it very difficult and costly to maintain information fresh. Therefore, a state-free solution might be more efficient and more viable since sensors will not be required to maintain routing or neighborhood tables.

One type of state-free data delivery technique is flooding-based data delivery [8], [9]. These protocols take advantage of the application-specific information, the location information, or other techniques to control the range of flooding to a desired extent. However, if the number of data sinks is far less than the number of sensors and different sinks require different sensing data, flooding-based solutions are very inefficient since sinks may receive too much unnecessary sensing data or too many additional copies of the same data packet delivered along different paths from sensors to sinks. The other type of state-free data delivery technique is competition-based and used in protocols such as Geographic Random Forwarding (GeRaF) [10] and Implicit Geographic Forwarding (IGF) [11]. The key idea in competition-based solutions is to allow, at each hop, next-hop candidate sensors to compete for the data forwarding task on the fly. The competition eliminates the need to select

<sup>2</sup>State here means information of the network topology or other sensors at a particular time.

the next-hop forwarding sensor at the sender or to find a path toward the data sink. Thus, the local or global states are not required to be constructed and maintained. In other words, such data delivery mechanisms do not require an individual routing protocol or a neighbor discovery protocol to build and maintain topology information or any other sensors' states before the actual data transmission.

In this paper, we propose a state-free network protocol, called State-free Implicit Forwarding (SIF), for multihop WSNs. Similar to GeRaF and IGF, SIF is based on geographical location of the nodes and selection of the forwarding node via competition among receivers. However, compared with GeRaF, SIF has a simpler and more efficient competition mechanism since SIF does not require a transmitter to send out positive feedback messages to help arbitrate the competition among receivers. Different from IGF, SIF does not assume a high node density. In fact, using a two-dimensional Poisson point process model [12], we analyze the probability of void in SIF, which is defined as the scenario when no next-hop forwarding sensor is available, and demonstrate that SIF can work well with a moderate node density. Further differences among these competition-based solutions are: i) the way in which multiple responses are prevented, ii) the calculation complexity of a forwarding area, iii) criteria to select a forwarding node, and iv) void handling techniques.

Our paper is organized as follows: The SIF protocol and its analysis are presented in Section II. Section III provides simulation results along with our discussions. In Section IV, we conclude this paper with a summary of our findings and future work.

## II. STATE-FREE IMPLICIT FORWARDING

### A. Assumptions

We make the following assumptions for the WSNs that we study in this work: a large number of sensors and a small numbers of stationary sinks are deployed over a field.<sup>3</sup> The user collects data via a sink that communicates with the sensor network. Unlike [4], [9], we assume that the sensors know what the data sinks are interested in or these interests have been propagated to the intended sensors via some mechanisms such as flooding or broadcasting.<sup>4</sup> Due to the limited radio range, data packets are usually forwarded over multiple hops before reaching a sink. Sensors know how far they are away from every sink. Such distance-to-sink information may be obtained from one of the following methods: pre-configuration if sensors and sinks are all stationary; distance estimation if sensors have an individual broadcast channel and sinks are able to reach them via this additional channel; GPS if sensors are configured with a GPS receiver; or localization algorithms [14], [15]. We further assume a symmetric communication channel, i.e., if node A is within the communication range of node B, then node B is also within the communication range

<sup>3</sup>In fact, the data sinks can be mobile as long as their locations are known to the sensors when sensing data is being collected.

<sup>4</sup>The study of these mechanisms is beyond the scope of this paper as we only focus on how sensing data can be delivered to data sinks.

of node A. Our SIF protocol includes the following building blocks<sup>5</sup> and we use one data sink to demonstrate how it works. The extension to multiple sinks is straightforward.

### B. Forwarding Area and Probability of Void

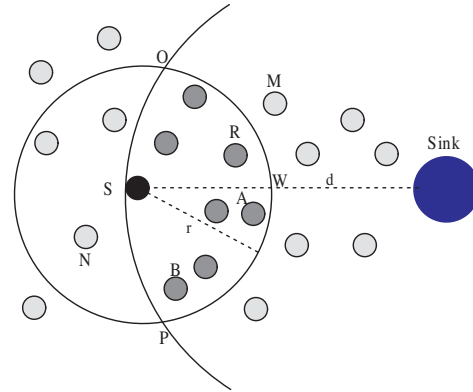

Fig. 2. Forwarding Area in SIF

Forwarding area is defined as the area where potential forwarding nodes reside. Figure 2 illustrates this area in SIF. The circle represents the transmission range of the sender  $S$ . The arc is centered at the data sink and with a radius of  $d$ , the distance between the sender and the data sink. Any sensor within this overlap region OSPW has a shorter distance to the sink than the sender  $S$  and becomes a forwarding candidate for the sender  $S$ . The size of the forwarding area depends on  $d$ . To demonstrate that our protocol works well with a moderate node density, we present a theoretical analysis for the probability of void as follows:

The sensor distribution in the region of interest can be modeled as a two-dimensional Poisson field. Thus, the probability that  $k$  sensors are located within an area of size  $A$  is given by [12]:

$$P(k) = \frac{(\lambda A)^k \times e^{-\lambda A}}{k!}, \quad (1)$$

where  $\lambda$  is the expected number of sensors within a unit area.

Let  $D$  be a random variable corresponding to  $d$  in Fig. 2, i.e.,  $D$  represents the distance between the sender  $S$  and the sink. Define an index random variable  $I$ :

$$I = \begin{cases} 1, & \text{at least one forwarding candidate is available;} \\ 0, & \text{otherwise.} \end{cases}$$

Note that the sender should send the data packet directly to the sink if  $D \leq r$  ( $r$  is the transmission range of the sender) regardless of the value of  $I$ . Therefore, the probability of void in SIF can be derived as:

$$P(\text{void}) = P((D > r) \cap (I = 0)), \quad (2)$$

<sup>5</sup>In this paper, we present the SIF protocol based on the IEEE 802.11 standard [17]. Note that the SIF protocol can be easily implemented in other similar forms.

While we cannot obtain a closed-form expression for (2), we may upper bound it by  $P(I = 0)$ , which represents the probability that there is no sensor inside the forwarding area OSPW shown in Fig. 2. Note that the area OSPW increases with  $d$  when  $d \geq r$ . So, the minimum value of the area OSPW occurs at  $d = r$ . Since the probability  $P(k = 0)$  decreases with  $A$ , the probability of void is upper-bounded by:

$$P(\text{void}) \leq e^{-\left(\frac{2}{3} - \frac{\sqrt{3}}{2\pi}\right)\rho}, \quad (3)$$

where  $\rho = \pi r^2 \lambda$  denotes the average number of sensors within the transmission range  $r$  of the sender. From the upper bound, it can be calculated that the probability of void is less than 15% when  $\rho$  is 5. When  $\rho$  is increased up to 10 and 15, it decreases to 2.1%, 0.3%, respectively. Considering that this is an upper bound, the actual values are even smaller as  $D$  increases.

### C. SIF Handshake

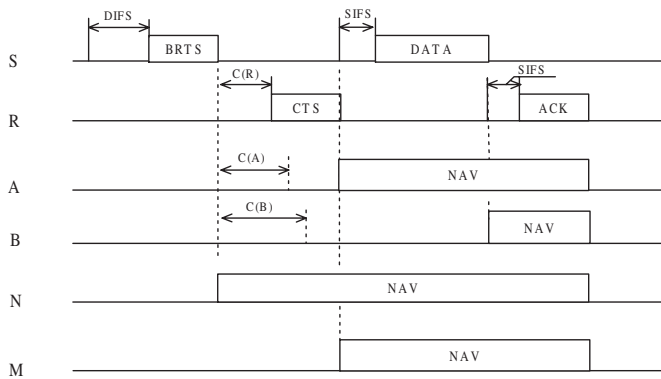

Fig. 3. SIF Handshake

Frame Control	Duration	Distance-to-Sink	RA	TA	FCS
---------------	----------	------------------	----	----	-----

Fig. 4. BRTS frame format

Figure 3 elaborates the process of a SIF handshake. The sender S that wants to send a data packet senses the medium physically and virtually. If the medium is determined to be free for a DCF Interframe Space (DIFS) time, the sender S sends a broadcast RTS (BRTS) to all neighbors in its transmission range. Otherwise, the protocol obeys the IEEE 802.11 specification and defers its transmission. The distance-to-sink information of the sender S is carried in the BRTS, which is shown in Fig. 4. The sensors receiving this BRTS packet will compare its distance-to-sink with the sender's announced value. Those sensors with smaller distance-to-sink, such as sensors R, A, and B in Fig. 2, will automatically become the forwarding candidates. Each candidate sets a timer which defines a corresponding amount of time that must elapse before replying to the BRTS packet. We explain how to define this amount of time (called competing response time) in

Section II.D. Other sensors that are outside of this forwarding area but within the communication range of S, e.g., sensor N, set their Network Allocation Vector (NAV) values. The sensor with the earliest timeout, e.g., sensor R in Fig. 2, will respond to the sender S with a CTS, which contains its own address/identifier and confirms the successful reservation of the channel. The sender S then unicasts its data packet to sensor R. Sensor R will pick up the data packet and reply with an ACK to indicate the end of this handshake. The handshake process described above is repeated whenever a data packet needs to be transmitted toward the data sink.

To avoid multiple CTS responses, every forwarding candidate monitors the channel for any transmission during their waiting time. Whenever a CTS, which responds to the sender S, is heard, they are aware that another sensor with an earlier timeout has sent out its CTS reply. They will cancel their CTS responses and update their NAVs. Note that, in the forwarding area, some sensors might be out of the transmission range of others. Hence, when a transmission carrier is sensed on the channel, they will assume that another sensor with an earlier timeout exists. They will then defer their CTS replies. Once they hear a following data packet from the sender S, they will be certain of their assumptions and quit the competition. Note that the maximum distance between any two candidates in the forwarding region is less than twice the value of the transmission range. The correct operation of our SIF protocol is guaranteed by the fact that the carrier sensing range is usually 2.2 times<sup>6</sup> the transmission range [13].

One potential problem of the SIF scheme is that duplicated data packets may be delivered. In fact, if the ACK packet is lost, the forwarding sensor has already received the data packet while the sender is not aware of the successful transmission. Now two sensors have the same data packet and both will try to forward them to the data sink. It will be very difficult to detect and eliminate such duplicated data deliveries, since the forwarding sensors do not maintain any state/record for the forwarded packets and the retransmission may employ another forwarding sensor which is not aware of any such successful transmission. We argue that the possibility of losing ACK packet is relatively small in SIF. Therefore, the effect of duplicated data packets is limited. It is also noted that our handshake exploits the IEEE 802.11 RTS/CTS exchange to protect the network from the hidden terminal problem to a satisfactory extent and it loses almost no MAC bandwidth efficiency compared with the IEEE 802.11 protocol.

### D. Competing Response Time

The competing response time is an amount of time that must elapse before replying to a BRTS packet. The basic idea is to make the sensors which are closer to the sink and have more residual energy take the forwarding responsibility with a higher probability. The introduction of a random value is to

<sup>6</sup>Although some recent 802.11 radios may not have this feature, we assume that these ranges in sensor radios can be adjusted to make them suitable for our protocol.

further disperse the system workload. An example function is introduced below:

$$C = \left[ W_d \cdot \left(1 - \frac{L}{T}\right) + W_e \cdot \left(1 - \frac{R_e}{E}\right) + W_r \cdot V \right] \cdot M, \quad (4)$$

where M is equal to DIFS and

$L$  = Distance-to-sink of the sender -  
Distance-to-sink of a forwarding sensor

$T$  = Transmission range of the sender

$R_e$  = Remaining energy

$E$  = Maximum energy

$V$  = Random value in (0, 1)

$W_d, W_e, W_r$  = Weights assigned to distance, energy  
and random value

$W_d + W_e + W_r = 1$

$M$  = Maximum competing response time

$C$  = Competing response time

Note that the value of C should be less than DIFS. Otherwise, other sensors in the neighborhood which have data packets to send may initiate a new handshake and interfere with the ongoing handshake.

### E. Handling Voids

Voids can still occur although its probability is quite low in WSNs with a moderate or higher node density, as shown in Section II.B. Such voids result in handshake failures and the loss of desired sensing data. Observing that voids could be the result of an absent or temporarily unavailable sensor, the sender should re-transmit a RTS up to a threshold value (say, 3 times, it is a protocol parameter which needs to be tuned). After that, the sender can declare the absence of candidates if no CTS response is received. Two possible techniques can be employed by SIF to handle voids: i) The sender gradually increases its transmission range until at least a forwarding sensor is found. ii) Sensors can dynamically adjust their status (e.g., active or inactive). Once a sensor cannot locate any forwarding sensors in the neighborhood, it should mark itself as a dead-end sensor, go into the inactive status, and discourage itself from sending or forwarding any sensing data. The sensor can go back to the active status if it finds forwarding sensors at a future time due to recently awake or newly arrived sensors in the forwarding area.

### F. Pseudo Code

We provide a simplified version of the pseudo-code for SIF in Figure 5. The main differences between the SIF and the IEEE 802.11 protocols are summarized in Figure 6.

## III. SIMULATION RESULTS

We have implemented the SIF protocol using the NS2 (ns-2.26) simulator [16] and performed simulations to evaluate its performance. In this paper, our simulations focus on the

Sender	Receiver
<pre>// Whenever sender has a data packet Carrier sensing until (Channel is idle for at least a DIFS time and NAV is equal to 0);  // To initiate a SIF handshake Broadcast RTS; Set RTS_Wait timer;  If (RTS_Wait timer expires) {  // Check maximal re-transmission If (less than or equal to maximum) {   Backoff and re-transmit;   Add one transmission times; } else   Handle voids; }  // A CTS received before timeout else {   Receive a CTS response;  // Handshake continues with a specific node // The rest is similar to 802.11   Send data packet; } }</pre>	<pre>// Wait for a RTS Receive RTS; If (its distance-to-sink is less than sender's)   CTS_wait = Time(energy, distance); else   set NAV = Expected transmission time;  If (CTS_wait timer expires) {   Generate a CTS ready to send;  // Send CTS or eliminate its CTS response If (Channel is idle and NAV is 0)   Send CTS; else {   Defer and Carrier sensing ;   If (Data packet is heard) {     Cancel its ready CTS;     Set NAV;   } }  }  else {   If (CTS is heard) {     Cancel its CTS_wait timer;     Set NAV;   } }  // Handshake continues</pre>

Fig. 5. Pseudo Code for SIF

Items	IEEE 802.11	SIF
1	A single MAC protocol No next-hop node selection	An integrated data delivery protocol Next-hop node selection at transmission time
2	No location or distance information	Distance-to-sink awareness
3	A unicast RTS initiates handshake	A broadcast RTS initiates handshake
4	Normal RTS frame	Extended RTS frame that carries the distance-to-sink information
5	A CTS is sent after the Short Interframe Space (SIFS) period if the NAV is 0	Whether a CTS is sent or not depends on the current channel conditions and activities in the neighborhood

Fig. 6. The differences between SIF and IEEE 802.11

TABLE I  
SYSTEM PARAMETERS

Parameter	Values
Two-dimensional area	$150 \times 150 m^2$
Sensors	50 and 75
Data packet size	32 bytes CBR
Total packets sent	500 per sensor
Number of sensors that send data	3 per run
Sensor transmission range	40 m
Sensor carrier sensing range	88 m
DIFS/SIFS	$50\mu s/10\mu s$
Bandwidth	200 kbps
Location of the sink	(150 m, 150 m)

comparison of the data delivery performance of SIF, IGF, DSR over IEEE 802.11 both with and without RTS/CTS exchange. We evaluate the sensitivity of our protocol to different average node densities for a static network. To make our work as close as possible to the existing hardware for WSNs [18], we set our system parameters as shown in Table I. For each data point shown, we have calculated the average of 60 runs with different random seeds to have adequate confidence. Our evaluation metrics include Packet Delivery Ratio (number of non-duplicated data packets received at the sink/number of data packets generated by the sensors), average end-to-end Packet Delay (average network latency of received data packets), and Normalized Overall Communication Overhead (total number of packets sent at the MAC layer/Packet Delivery Ratio). Note that we turn off our voids handling function<sup>7</sup> in SIF for a fair comparison with IGF since IGF does not have an integrated void handling mechanism.

We consider two sets of experiments with different average node densities for comparison. Two sensing fields, in which 50 and 75 sensors are distributed based on a two-dimensional Poisson process over an area of size  $150 \times 150m^2$ . They represent two different average node densities  $\rho = 11.2$  and  $16.8$ , respectively. As shown in Table I, in each run of simulation, there are 3 sensors sending 500 packets of size 32 bytes at a fixed rate to the sink which is located at the upper right-hand corner of the region of interest, while the rate changes in different configurations from an initial  $1 \text{ packet/second}$  to  $19 \text{ packets/second}$  in steps of  $2 \text{ packets/second}$ . We set the probability of channel packet error rate (PER) to 0.05. The simulation results are presented in Figs. 7 and 8.

From these simulation results, we observe that SIF has a much higher packet delivery ratio than IGF for  $\rho = 11.2$ , and slightly higher than IGF for  $\rho = 16.8$ , while DSR/802.11 (whether RTS/CTS is on or off) loses packets early as it quickly congests the network by sending route discovery packets and this problem becomes more serious under a higher node density. When sensor transmission rates become sufficiently large to congest the network, the performance of DSR quickly degrades and it drops a large number of data packets due to the increased collisions between sensors and unstable routing information, especially when the RTS/CTS exchange is turned on. Both SIF and IGF perform well under heavy loads. However, under lower node density, IGF drops some percentage of data packets due to the existence of voids. Thus, IGF also has a lower packet delivery ratio compared with DSR under light loads when the average node density is not high enough for IGF to avoid voids. We also see that SIF has a lower average end-to-end packet delay than IGF under moderate node density. This is mainly because IGF has to re-initiate the handshake three times before it drops a pending data packet, which delays normal data packet transmission over the shared medium. Note that DSR has a

<sup>7</sup>Since the probabilities of void under the simulated scenarios in this paper are so low that SIF almost does not need to handle voids, the performance of SIF with and without voids handling is very close. We ignore the performance of SIF with voids handling here to avoid cluttered figures.

much higher packet delay because of the delay induced by its route discovery phase. The simulation results also demonstrate large communication overhead savings by SIF. Due to the use of routing and Address Resolution Protocol (ARP) packets in DSR, its communication overhead is several times higher than both SIF and IGF. It is observed that network performance of IGF becomes closer to that of SIF under a higher node density. Our simulation results further show that SIF can work well with a moderate node density, even though it does not have the voids handling mechanism turned on in this experiment.

We have also performed preliminary evaluations of SIF under node mobility. The simulation results are not presented in this paper due to page limits. The preliminary results show its insensitivity to node mobility due to the intrinsic state-free feature. The results also demonstrate its performance advantages over IGF and DSR for mobile WSNs. We are performing a more accurate evaluation which considers the additional overhead of obtaining accurate distance-to-sink information when sensors are moving.

#### IV. CONCLUSIONS

Wireless sensor networks have been envisioned as extremely resource-constrained networks. The requirement of maintaining states in state-based routing protocols in WSNs makes them very inefficient due to the extra communication overhead. The high network dynamics further exacerbates this situation and requires costly state maintenance for the up-to-date information. In this paper, we have proposed the SIF protocol, which combines the tasks of routing and MAC via cross-layer design, to deliver sensing data from sensors to data sinks for such wireless sensor networks, in which the number of stationary sinks is far less than the number of sensors. Our solution is based on the idea of an immediate competition between receivers at the transmission time, eliminating the requirement of global or local state maintenance.

Using a two-dimensional Poisson point process model, we show that SIF has a very high probability of finding a forwarding sensor with a moderate node density. In performance evaluation, we have compared our protocol with IGF and DSR over 802.11, showing that SIF outperforms these protocols during data delivery in terms of communication overhead, packet delivery ratio, and average packet delay, under different node densities. Our future research work will include a comprehensive protocol performance analysis, comparison, and study of SIF with other existing data delivery protocols or mechanisms in WSNs, through analytical and simulation methods.

#### REFERENCES

- [1] I. F. Akyildiz, W. Su, Y. Sankarasubramaniam, and E. Cayirci, "A Survey on Sensor Networks," in *IEEE Communications Magazine*, Vol. 40, No. 8, pp. 102-114, August 2002.
- [2] G. Pottie and W. Kaiser, "Wireless Integrated Network Sensors," in *Communications of ACM*, Vol. 43, No. 5, pp. 51-58, May 2000.
- [3] D. B. Johnson and D. A. Maltz, "Dynamic Source Routing in Ad Hoc Wireless Networks," in *Mobile Computing*, 1996.
- [4] C. Intanagonwiwat, R. Govindan, and D. Estrin, "Directed Diffusion: A Scalable and Robust Communication Paradigm for Sensor Networks," in *Proc. of MobiCom '00*, Boston, MA, USA, August 2000.

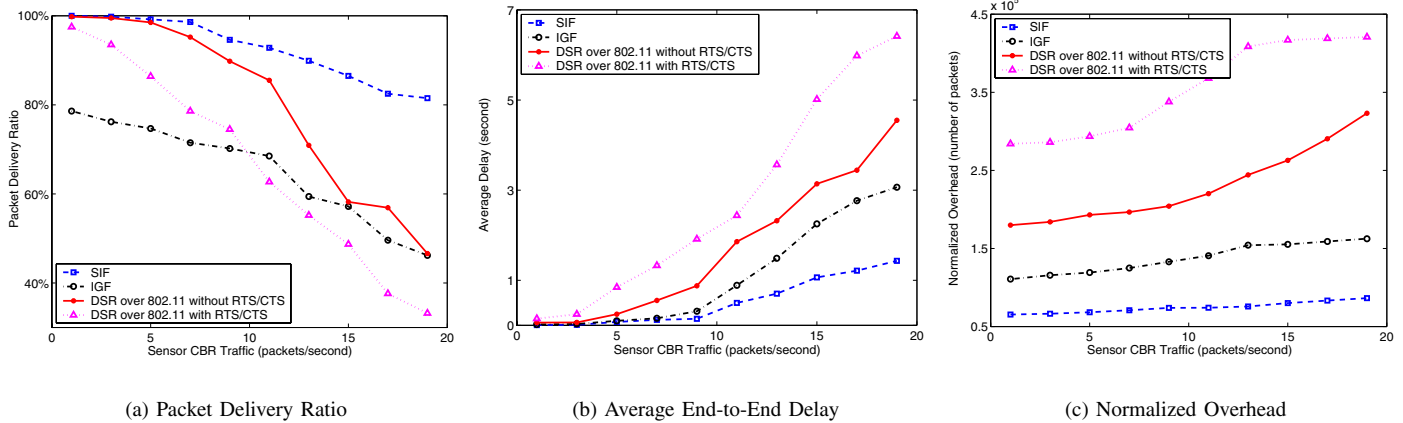

Fig. 7. Simulation results for a static network with average node density  $\rho = 11.2$

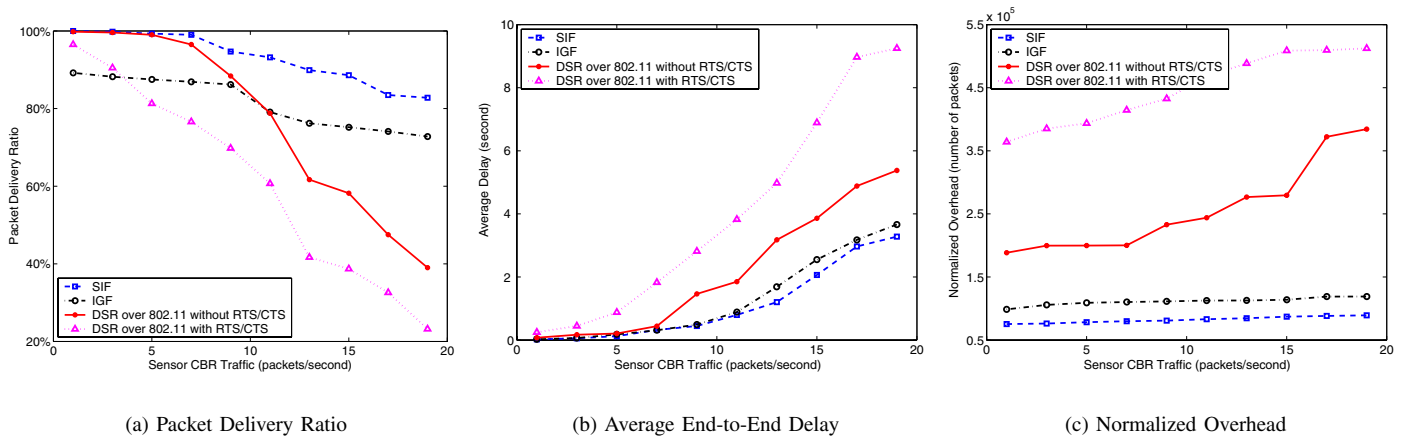

Fig. 8. Simulation results for a static network with average node density  $\rho = 16.8$

- [5] B. Karp, "Geographic Routing for Wireless Networks," in *Ph.D. Dissertation*, Harvard University, Cambridge, MA, October, 2000.
- [6] Y. Ko and N. H. Vaidya, "Location-Aided Routing (LAR) in Mobile Ad Hoc Networks," in *Proc. of MobiCom'98*, Dallas, TX, USA, October 1998.
- [7] B. Karp, and H.T. Kung, "Greedy Perimeter Stateless Routing for Wireless Networks," in *Proceedings of MobiCom 2000*, Boston, MA, August, 2000, pp. 243-254.
- [8] W. R. Heinzelman, J. Kulik, and H. Balakrishnan, "Adaptive Protocols for Information Dissemination in Wireless Sensor Networks," in *Proc. of MobiCom'99*, Seattle, Washington, 1999.
- [9] F. Ye, G. Zhong, S. Lu, L. Zhang, "GRAdient Broadcast: A Robust Data Delivery Protocol for Large Scale Sensor Networks," *ACM WINET (Wireless Networks)*.
- [10] M. Zorzi, R.R. Rao, "Geographic Random Forwarding (GeRaF) for ad hoc and sensor networks: multihop performance," in *IEEE Trans. on Mobile Computing*, vol. 2, Oct.-Dec. 2003.
- [11] B. M. Blum, T. He, S. Son, and J. A. Stankovic, "IGF: A Robust State-Free Communication Protocol for Sensor Networks," in *Technical report CS-2003-11*, CS Department, University of Virginia, 2003.
- [12] J. L. Gao, "Analysis of energy consumption for ad hoc wireless sensor networks using a bit-meter-per-joule metric," in *IPN Progress Report*, 42-150, August 2002.
- [13] S. Xu, T. Saadawi, "Does the IEEE 802.11 MAC Protocol Work Well in Multihop Wireless Ad Hoc Network," in *IEEE Communications Magazine*, pages 130-137, June 2001.
- [14] A. Sawides, C.-C. Han, and M. B. Strivastava, "Dynamic Fine-grained Localization in Ad-Hoc Networks of Sensors," *Proc. of MobiCom 2001*, Rome, Italy, July 16-21.
- [15] N. Bulusu, J. Heidemann, and D. Estrin, "GPS-less Low Cost Outdoor Localization For Very Small Devices," *IEEE Personal Communications Magazine*, 7(5), pp. 28-34, Oct. 2000.
- [16] K. Fall and K. Varadhan, "The NS Manual," UC Berkeley, LBL, USC/ISI, Xerox PARC, 2002: <http://www.isi.edu/nsnam/ns/>.
- [17] "IEEE Standard for Wireless LAN - Medium Access Control and Physical Layer Specification, P802.11," 1999.
- [18] "XBOW MICA Mote Specifications," <http://www.xbow.com/Products/products.htm>.